



SISTEMA DE GESTIÓN DE COMBUSTIBLE



DISPENSADORES



KITS



BOMBAS



MEDIDORES



PISTOLAS

VISCOMAT VANE

CARACTERÍSTICAS

- VERSATILIDAD
- PORTÁTIL Y LISTA PARA USAR
- BOMBA MULTIUSOS
- DERIVACIÓN REGULABLE

PIUSI VISCOMAT VANE es una bomba eléctrica de paletas adecuada para todas aquellas aplicaciones en las que es necesario utilizar un sistema de transferencia con gran capacidad de succión para poder transferir líquidos de viscosidad media-alta, de hasta 500 cSt. La bomba está equipada con un motor asíncrono autoventilado, cerrado y disponible en distintas tensiones y frecuencias, con el fin de adaptarse a cualquier circunstancia de trabajo.



RENDIMIENTO

HASTA

50 L/MIN

CAUDAL

FUNCIONAMIENTO

CA

CONTINUO
ALIMENTACIÓN

HASTA

500 CST

VISCOSIDAD



VISCOMAT VANE



PACKAGING

CÓDIGO	PESO		PACKAGING			N. BOX / EUROPALET	
	KG	LBS	MM	PULGADAS	UDS./CAJA	✈	🚚
VISCOMAT 70							
FO033490A	14,1	31,1	355X185X285	-	1	60	72
FO033190A	14,1	31,1	350X200X280	-	1	60	72
VISCOMAT 90							
FO0303M00	14,1	31,1	350X200X280	-	1	60	72
000303000	14,1	31,1	350X200X280	-	1	60	72



FILTRACIÓN



MONITOREO DE DEPOSITO



ENROLLADORES DE MANGUERA



ACCESORIOS



MATERIAL PROMOCIONAL



AIRE



ANTICONG.



AdBlue®



BIODIÉSEL



DIÉSEL



ALIMENTOS



GASOLINA



GRASA



QUEROSENO



ACEITE



AGUA



LIMPIAPARAB.

GRÁFICO

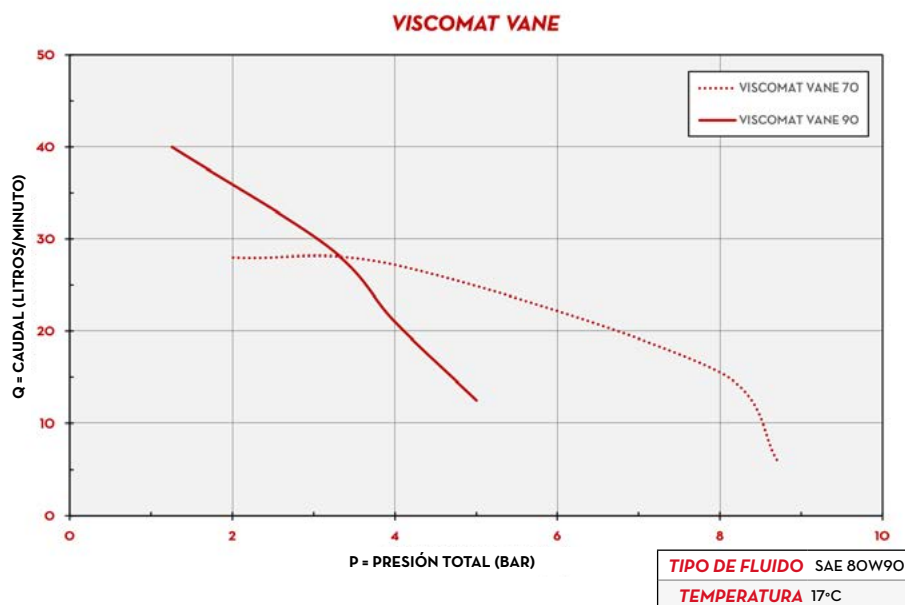

DIMENSIONES

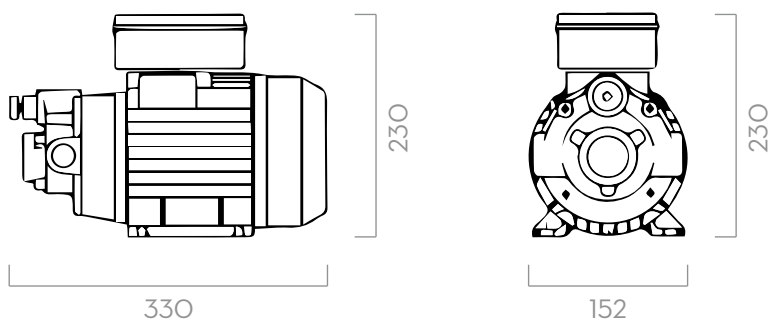

Las dimensiones se expresan en milímetros

CONTENIDO DE LA CAJA

- BOMBA VISCOMAT VANE
- MANUAL DE INSTRUCCIONES

DETALLES

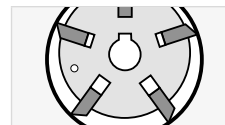

MATERIALES

- CUERPO: HIERRO FUNDIDO
- ROTOR: ACERO SINTERIZADO
- PALETAS: TECNOPOLÍMERO
- EJE: ACERO



BOMBA

- > MÁX. 6 M (20 FT),
- > MANGUERA DE SUCCIÓN Ø 1" MÍN.,
- > ALTURA MÁX. DE SUCCIÓN:
 - 2M (7FT) SIN VÁLVULA ANTIRRETORNO
 - 4M (14FT) CON VÁLVULA ANTIRRETORNO



DEPÓSITO

FICHA TÉCNICA

CÓDIGO	DESCRIPCIÓN	TIPO DE FLUIDO	CAUDAL		PRESIÓN		TENSIÓN				RPM	ENTRADA/SALIDA BSP	AJUSTABLE VÁLVULA DERIVACIÓN
			L/MIN	GPM	BAR	PSI	MOTOR MONOFÁSICO V/HZ	MOTOR TRIFÁSICO V/HZ	POTENCIA/VATIOS	AMP. MÁX.			
VISCOMAT 70													
FO033490A	VISCOMAT 70 M 230/50-60	D O B	25	7	6	85	230/50-60	-	1200/1100	5,5 - 5,1	1470/1650	1"	SÍ
FO033190A	VISCOMAT 70 T 400/50-60	D O B	25	7	6	85	-	400/50 - 400/60	650/1000	2,2 - 3,1	1450/1750	1"	SÍ
VISCOMAT 90													
FO0303M00	VISCOMAT 90 M 230/50-60	D O B	50	13	5	71	230/50-60	-	1350/1600	6,2 - 4,9	1400/1600	1"	NO
000303000	VISCOAMT 90 T 400/50	D O B	50	13	5	71	-	400/50	2000	5	1450	1"	SÍ

SE PUEDE PEDIR CON DIFERENTE TENSIÓN Y FRECUENCIA

VISCOMAT VANE